

514 FIRE - ALL Oil Burners are rugged, maintenance-free, sealed-in burners for burning light or heavy oil for a wide variety of applications. Capable of efficient operation through a wide temperature range, they are equally at home on low temperature ovens and high temperature forge and melt furnaces.

Sealed mountings help maintain furnace pressure, controlled atmosphere, and closer fuel/air ratio control — all contributing to better product quality.

Fire-All Burners have been used for years with great success on all types of furnaces.

Combustion Characteristics

514 Burners are stable with 200% or more excess air. They may also be operated with excess fuel without forming carbon if additional combustion air is available in the furnace near the burner. Excess fuel limit with heavy oil is 50% as atomization deteriorates at richer ratios.

Burners can be turned down to atomizing air only, but stability limits vary depending on burner size, grade of oil, and furnace ambience – please consult CONTITHERM regarding minimum oil rates for your specific application.

For prolonged operation on atomizing air only in furnaces over 1600°F specify an alloy burner nose.

Burners are suitable for some preheated combustion air applications (upto 700°F): consult CONTITHERM

Oil viscosity at the burners should not exceed 100 SSU; oil pressure at the Ratiotrol should be between 25 and 30psi. Minimum atomizing air pressure at the burner is 14 osi for light oil, 22 osi for heavy oil.

Table 1. Total Capacities
(including main and atomizing air)

Burner designation	16 osi Air pressure drop across burner		24 osi Air pressure drop across burner	
	Air-cfh	Oil-gph†	Air-cfh	Oil-gph†
514-6	17 900	13	21 900	16
514-7	28 400	20	34 800	25
514-8-A	48 900	35	60 000	43
514-8-B	81 500	58	100 000	71
514-9	165 000	118	202 000	144
514-10	247 000	176	303 000	216

† Oil capacities are based on 140 000 Btu/gallon

Table 2. Main Air Capacities in scfh
Multiply by 100 to get Btu per hour

Burner designation	Air pressure drop across the burner in osi							Approx. Flame Lengths with 16 osi Main Air (in open furnace)
	0.1	1	5	6	8	12	16	
514-6	1 180	3 710	8 300	9 100	10 500	12 900	14 900	5'
514-7	1 930	6 100	13 600	15 000	17 200	21 000	24 400	5-6'
514-8-A	3 350	10 600	23 700	26 000	30 000	36 700	42 400	8-9'
514-8-B	5 550	17 600	39 200	43 000	49 600	60 500	70 000	9-12'
514-9	11 600	36 600	82 000	89 500	104 000	127 000	146 000	15-18'
514-10	17 300	54 500	122 000	135 000	154 000	189 000	218 000	20'

Table 3. Atomizing Air Capacities in scfh
Multiply by 100 to get Btu per hour

Burner designation	Air pressure drop across the burner in osi					
	14	16	18	20	22	24
514-6	2 800	3 000	3 180	3 360	3 510	3 660
514-7	3 770	4 030	4 270	4 500	4 720	4 900
514-8-A	6 050	6 500	7 000	7 300	7 600	7 850
514-8-B	10 600	11 300	12 000	12 700	13 200	13 800
514-9	17 200	18 400	19 600	20 700	21 600	22 500
514-10	27 200	29 100	30 900	32 600	34 100	35 500

Flame Supervision. Purge UV with cleaning air to keep oil fog off the lens.

Use interrupted pilots with flame supervision – pilots should be on only for a preset ignition period (usually 15 seconds) after which flame supervision monitors main fire only.

Tile/Installation. Burner tiles are cast refractory rated for 2800° F furnace temperature. They should be supported securely in the furnace wall by a layer of castable refractory (not insulation) at least 9" thick all around the tile, extending back to the furnace shell and securely anchored to it. (See Supplement DF-M1.)

Tiles are replaceable in the field except for the 514-10, whose mounting must be returned to the factory for tile replacement (or purchase a spare mounting plate with a tile cast onto it). The - 10 size is also available with a short tile that extends 2" past the mounting plate. The remaining tile length is then field constructed.

For furnace walls thicker than the length of the tile, tunnel beyond the end of the tile should be flared at least 30°, starting at the OD of the tile. If this is not practical, consult CONTITHERM for specific recommendations.

Jacketed Tiles. 514 Burners are available with support jackets around the tile for applications where the tile is not supported by furnace refractory.

Jackets are available in three different metals and have maximum temperature ratings for each. They must be protected with sufficient insulation so as not to exceed rated temperature.

Maximum temperature rating for jacket metals depends upon frequency of heat-up/cool-down cycles. As an example, batch annealing furnaces that are heated and cooled everyday should use the "intermittent exposure" ratings. Continuous annealing furnaces that remain at the same temperature for months at a time, can use the higher "continuous" rating.

Designation	Jacket Metal	Continuous max. temp.	Intermittent exposure
514--LC	carbon steel	700°F	700°F
514--L4	304 stainless	1600°F	1500°F
514--L9	309 stainless	1900°F	1800°F

Complete burners include tile, mounting plate, Microtrol Oil Valve, and an observation port into which a small quantity of atomizing air is introduced to keep the glass clear. Order pilot tips separately.

CLEARANCE DIMENSIONS (for details, see Dimensions 614.)

Burner designation	Dimensions in inches					
	A	B	C	D	E	F
514 & 514-6-L	3	15	10 ³ / ₈	19 ¹ / ₂	15	9
514 & 514-7-L	4	16	11 ³ / ₈	20 ¹ / ₂	16 ¹ / ₂	9
514 & 514-8-AL	6	17 ³ / ₄	12 ³ / ₈	22 ³ / ₄	22 ¹ / ₂	10
514 & 514-8-BL	6	19	13 ¹ / ₂	24	23 ¹ / ₂	13
514 & 514-9-L	8	23	16	28	30	13 ¹ / ₂
514 & 514-10-L	10	27 ¹ / ₂	20 ¹ / ₂	32 ¹ / ₂	34	13 ⁷ / ₁₆

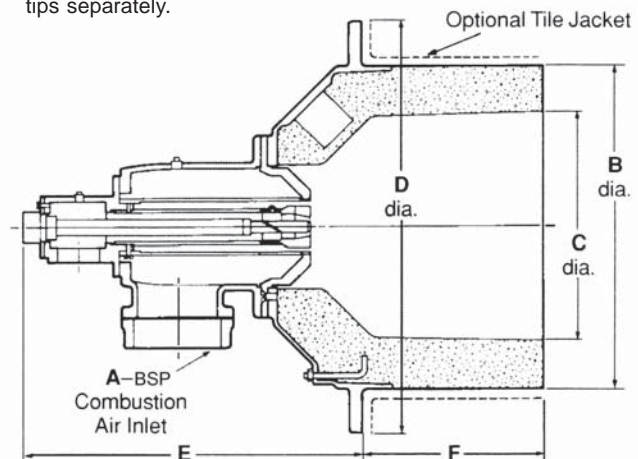

DIMENSIONS SHOWN ARE SUBJECT TO CHANGE. PLEASE OBTAIN CERTIFIED PRINTS FROM CONTITHERM IF SPACE LIMITATIONS OR OTHER CONSIDERATIONS MAKE EXACT DIMENSION(S) CRITICAL.



Plot No.150, 'S' Block, M.I.D.C., Bhosari, Pune - 411 026.
Telephone: (+91)-(20)-27129290 Mobile: (+91)- 7410077911, 9890007000
Email: rayenterprises@hotmail.com / Website: www.rayenterprisespune.com